

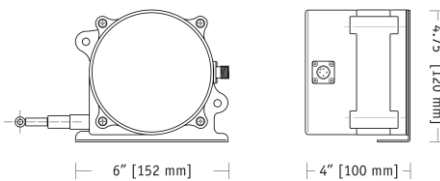

175-inch model shown



The SR1V is part of a series of rugged, low-cost, high performance string pots built for wet environments and outdoor applications. Designed for the rigors of outdoor construction equipment or the demands of a factory floor, the SR1M is the perfect low-cost solution for OEM and stocking distributors.

What sets this sensor apart from other string pots, is the internal programmable digital circuitry that gives the customer a one-size-fits-all approach for many applications. The SR1V ships factory calibrated to the full stroke range but the output signal can be easily re-scaled to match any stroke down to 1 inch (25 mm).

Output Signal

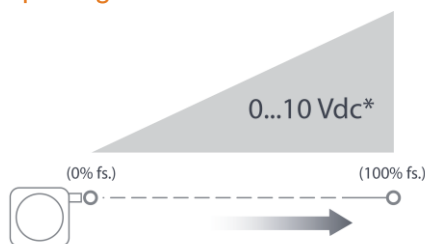

*Additional Output Options: 0...5, -5...+5, -10...+10 Vdc

SR1V

Cable Actuated Sensor Industrial • User Scalable VDC Output

User Adjustable Stroke Range to 175 inches (3 meters)

User Selectable 0-5, 0-10, -5-+5, -10-+10 VDC Output

Designed for Outdoor & IP67 environments

In Stock for Quick Delivery!

Specifications

Full Stroke Range, SR1V-125	125 inches (3175 mm), maximum
Full Stroke Range, SR1V-175	175 inches (4445 mm), maximum
Minimum Full Stroke Range	1 inches (25 mm)
Output Signal Settings	0-5, 0-10, -5-+5, -10-+10 VDC
Input Voltage	15-30 VDC (10-30 VDC for 0-5, -5-+5 volt signal)
Input Current	50 mA, max.
Maximum Output Load	20 mA
Accuracy, full stroke range ≥ 10 inches (254 mm)	.5% FS.
Accuracy, full stroke range < 10 inches (254 mm)	consult factory
Repeatability	.1% FS.
Resolution	.0015% FS.
Output Signal Update Rate	1 msec
Maximum Velocity	80 inches (2 meters) per second
Maximum Acceleration	10 g (retraction)
Measuring Cable Tension	23 oz. (6.4 N) ±30%
Sensor	plastic-hybrid precision potentiometer
Cycle Life	250,000 (potentiometer)
Enclosure	Polycarbonate
Measuring Cable	.034-inch dia. nylon-coated stainless
Electrical Connection	M12 Connector (mating plug included)
Environmental Suitability	NEMA 6, IP67
Operating Temperature	-40° to 185° F (-40° to 85° C)
Weight	2.5 lbs. (1.3 Kg)

Electrical Connection

output signal	connector pin	colorcode (cordset)
15...30 vdc	1	brown
output signal	2	white
common	3	blue
n/c	4	black

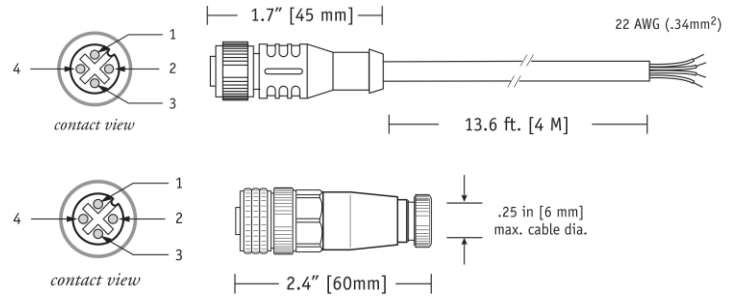

Factory Calibrated Stroke Range

The full scale output signal is set at the factory to the maximum full stroke range. The ZERO point (output = 0 Vdc) is set at the beginning* of the stroke range (0 inches) and the SPAN point (output = 10 Vdc) is set to the end of the range (125 inches or 175 inches depending on model).

**Important* — The ZERO point is set at the factory with the measuring cable pulled out .125 inches from full retraction.

This is for the factory setting only and the ZERO may be reprogrammed at full retraction at any time.

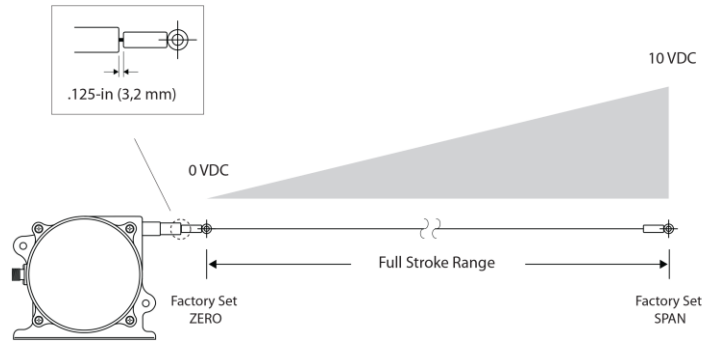

Cable Exit Direction Options

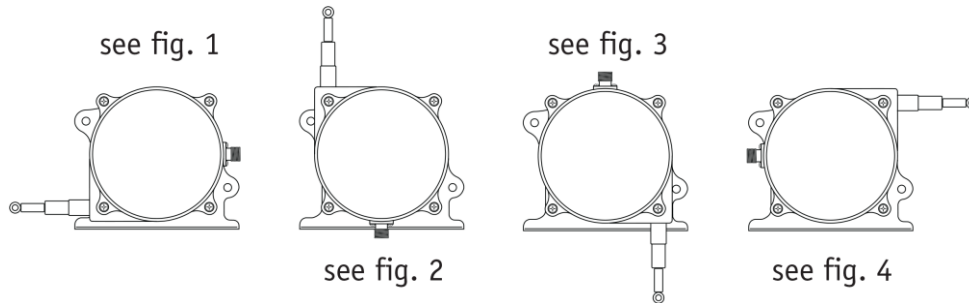

Changing the Cable Exit

Changing Measuring Cable Exit

To change the direction of the measuring cable, remove the 4 mounting bracket screws and rotate bracket to one of four available positions. See figures 1 - 4 on the following pages for mounting dimensions.

Changing Electrical Connector Direction

To change the position of the electrical connector, remove the 4 rear cover screws and carefully separate rear cover from the sensor body.

Rotate the rear cover to desired position being careful to not tangle the wiring harness that runs to the connector.

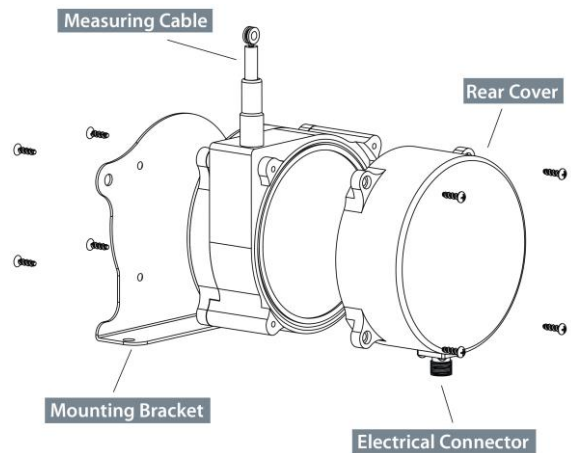

Internal Controller Board

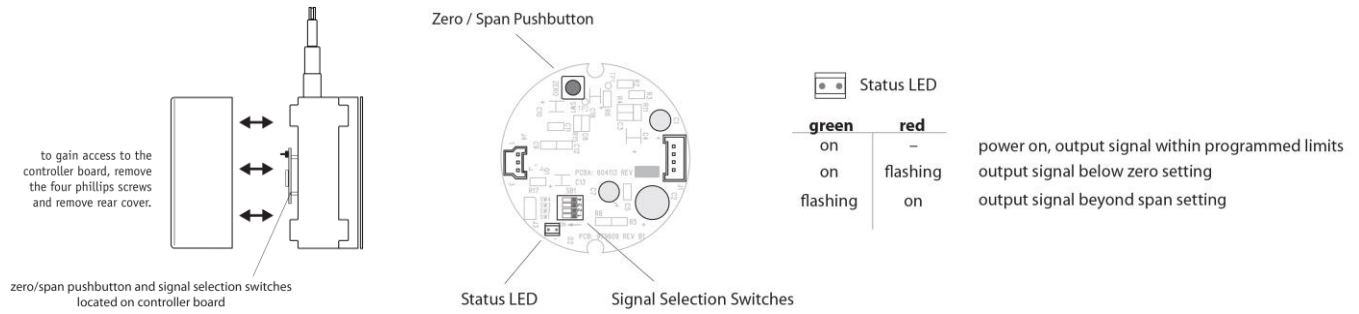

Changing Output Signal

Reprogramming ZERO and SPAN:

Reprogramming ZERO and SPAN:

Though ZERO and SPAN points have been preset at the factory, they can easily be changed to match any desired stroke within the full stroke limits of the sensor. To reprogram the SR1V to your own settings, remove the rear cover to gain access to the internal controller board. Locate the push-button on the circuit board and follow the instructions below.

Please note that ZERO and SPAN points can be set independently. You can set one without setting the other. This operation must be performed with the sensor under power. *Important: when you are finished, disconnect power for a couple of seconds to permanently set your new settings.*

Setting Span:

Set the cable to the desired SPAN limit then depress and hold the button until the STATUS LED begins to flash RED. Release the button (when the LED is flashing RED, not GREEN) and the flashing will slow down to about two-second intervals which indicates the SPAN value is being set into memory. When completed, the STATUS LED will display solid GREEN.



Setting Zero:

Set the cable to the desired ZERO limit and then depress and hold the button until the STATUS LED begins to flash GREEN. Release the button (when the LED is flashing GREEN, not RED) and the flashing will slow down to about two-second intervals which indicates the ZERO value is being set into memory. When completed, the STATUS LED will display solid GREEN. Remove power for 2 seconds then reconnect.

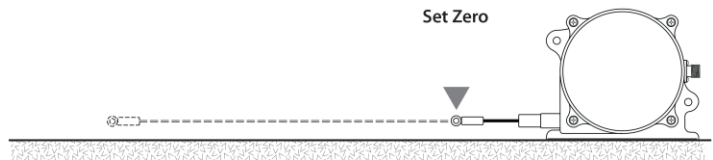

		switch settings			
zero	span	SW1	SW2	SW3	SW4
0 ... 5		off	off	off	off
5 ... 0		on	off	off	off
0 ... 10		off	off	off	on
10 ... 0		on	off	off	on
-5 ... +5		off	off	on	off
+5 ... -5		on	off	on	off
-10 ... +10		off	on	off	off
+10 ... -10		on	on	off	off

output signal options (VDC)

The SR1V leaves the factory set with a 0...10 VDC full scale output signal. The signal can be reversed or changed to either 0...5, -5...+5 or -10...+10 VDC (see illustration) by simply changing a dipswitch located on the controller board.

If you wish to simply reverse the output signal or change it to a different voltage range, you may do so without resetting the "zero" and "span" points.

Remove the rear cover to gain access to the board.

Fig. 1 - Outline Drawing (as shipped)

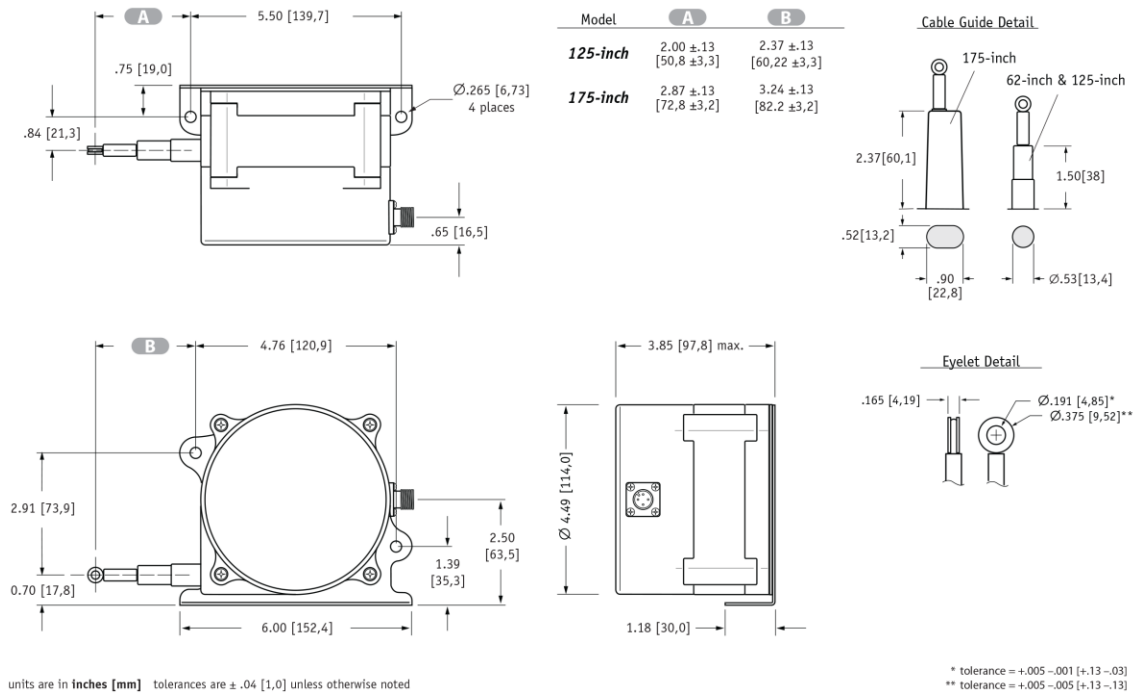

Fig. 2 - "Up" Cable Exit Direction

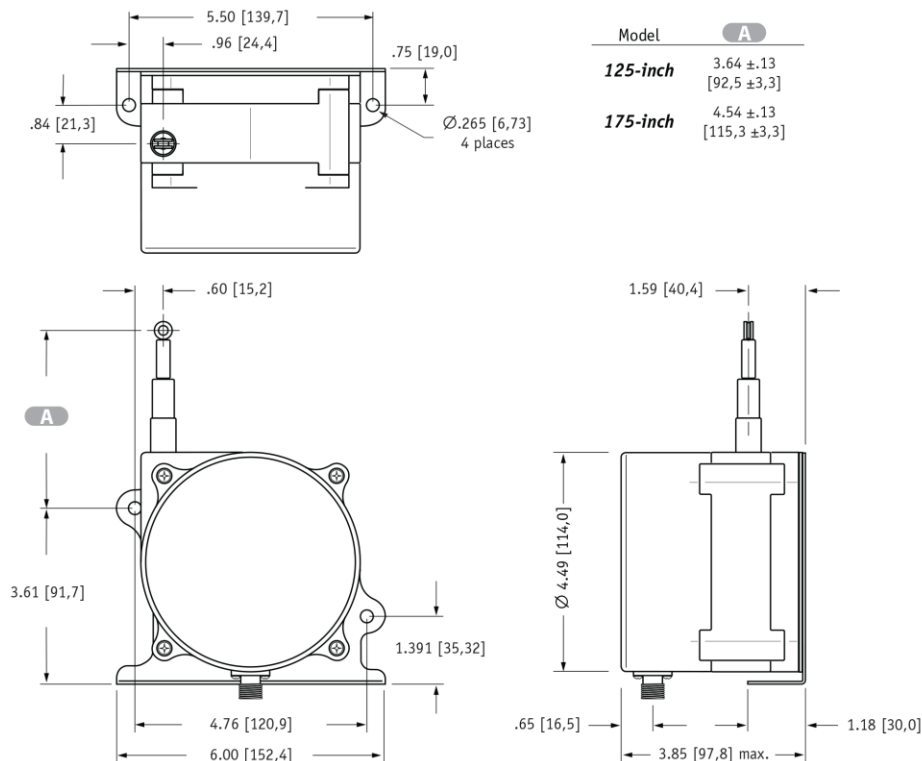

Fig. 3 - "Down" Cable Exit Direction

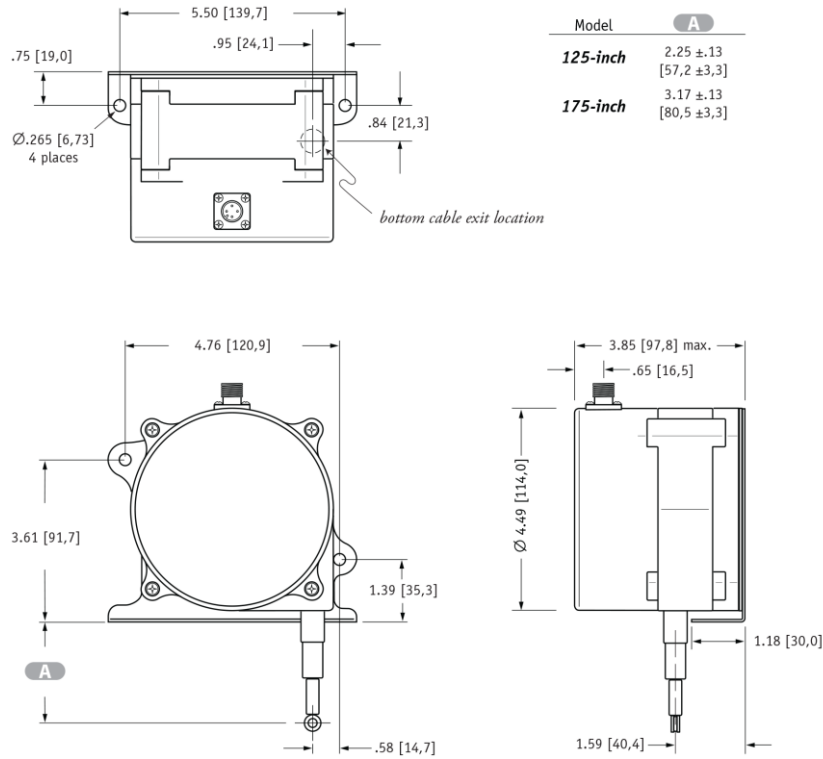
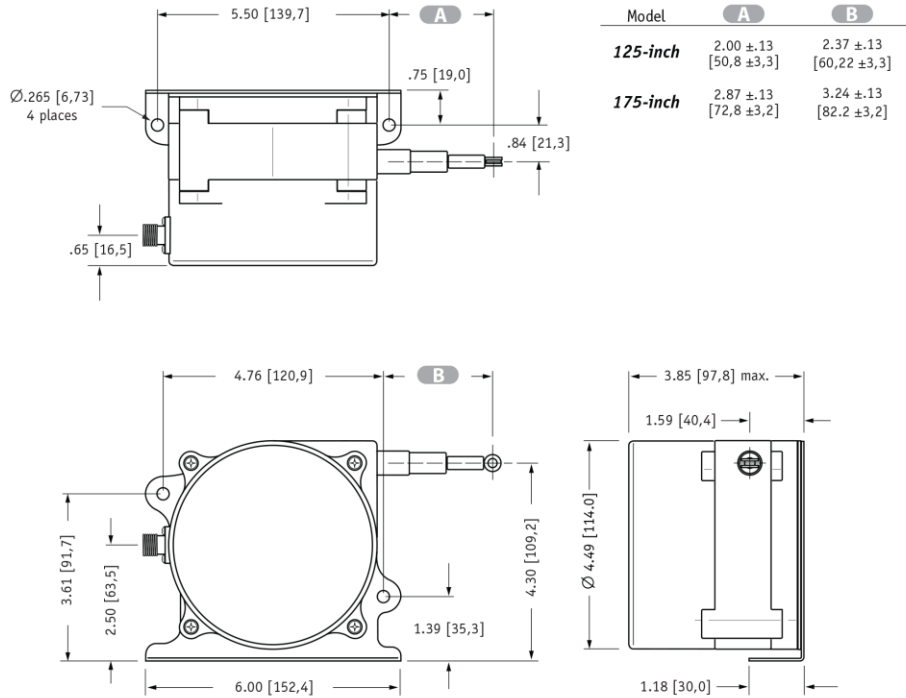

Fig. 4 - "Rear" Cable Exit Direction



units are in inches [mm] tolerances are ± .04 [1,0] unless otherwise noted

SPD

SPD Compact, High-Performance • Dual Output to 50"

Ordering Information

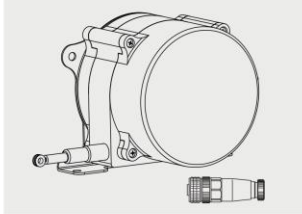

Order No.

SR1V-125

125-inch stroke range,
0–10 Vdc output,
4-pin M12 mating plug &
mounting bracket included.

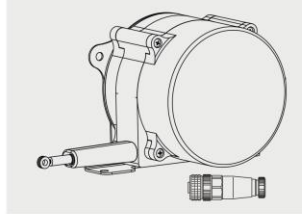

Order No.

SR1V-175

175-inch stroke range,
0–10 Vdc output,
4-pin M12 mating plug &
mounting bracket included.

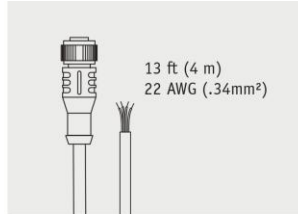

Order No.

9036810-0040

for short-run connections,
optional 13-ft cordset
with 4-pin M12 mating
plug.

NORTH AMERICA

Measurement Specialties, Inc.,
a TE Connectivity company
20630 Plummer Street
Chatsworth, CA 91311
Tel +1 800 423 5483
Tel +1 818 701 2750
Fax +1 818 701 2799
info@celesco.com

TE.com/sensorsolutions

Measurement Specialties, Inc., a TE Connectivity company.

Measurement Specialties, TE Connectivity, TE Connectivity (logo) and EVERY CONNECTION COUNTS are trademarks. All other logos, products and/or company names referred to herein might be trademarks of their respective owners.

The information given herein, including drawings, illustrations and schematics which are intended for illustration purposes only, is believed to be reliable. However, TE Connectivity makes no warranties as to its accuracy or completeness and disclaims any liability in connection with its use. TE Connectivity's obligations shall only be as set forth in TE Connectivity's Standard Terms and Conditions of Sale for this product and in no case will TE Connectivity be liable for any incidental, indirect or consequential damages arising out of the sale, resale, use or misuse of the product. Users of TE Connectivity products should make their own evaluation to determine the suitability of each such product for the specific application.

© 2015 TE Connectivity Ltd. family of companies All Rights Reserved.

SR1V 12/01/2015